



AVK COLLAR PIPE ADAPTOR
Hinged / Snap closure
For Certus valves sizes OD20 up to OD180

85/12
100
PP/CPA

AVK collar downpipe adaptors are suitable for PE100 ball valves in the isolation of gas and water services to domestic, commercial and industrial premises. The robust collar downpipe adaptor is designed and manufactured to withstand the most harsh environments.

Features

- Snap closure feature allows manual assembly and disassembly of the adaptor on installed valve
- Suitable for 90mm, 100mm and 110mm downpipes
- Centers downpipe on top of the valve enabling valve operation at all times
- 100% recyclable

Accessories/Options

- Downpipe
- Surface box adaptor
- Surface box



AVK COLLAR PIPE ADAPTOR
 Hinged / Snap closure
 For Certus valves sizes OD20 up to OD180

85/12
100
PP/CPA

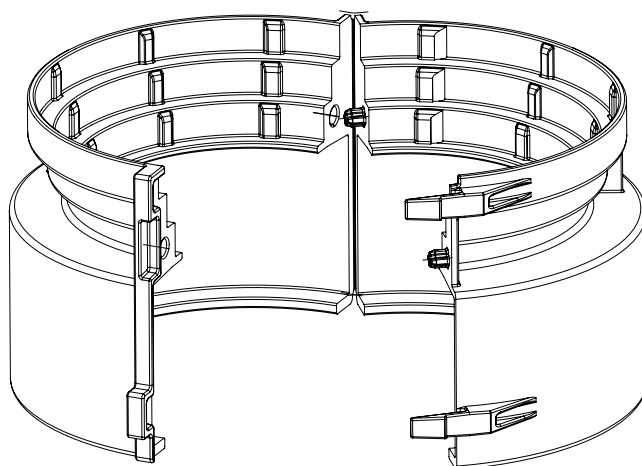
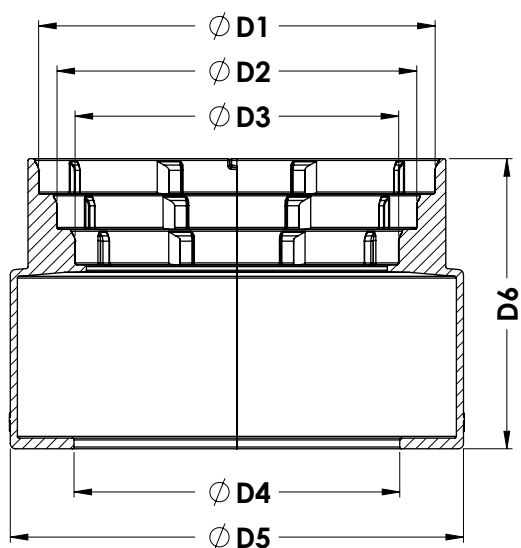
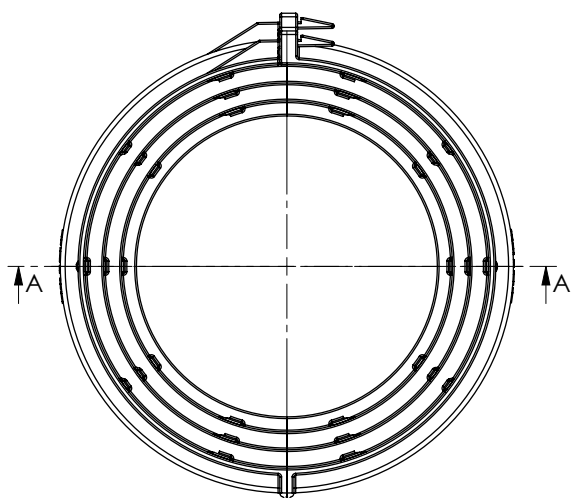

Component list

Collar pipe adaptor	PP
---------------------	----

Reference nos. and dimensions

AVK ref. nos.	Suitable for valve size	D1 mm	D2 mm	D3 mm	D4 mm	D5 mm	D6 mm	Weight kg
85-050-12100	DN25-DN50	112	102	91	69	128	82	0.1
85-080-12100	DN80	112	102	91	85	128	82	0.1
85-100-12100	DN100	112	102	91	92	128	82	0.1
85-150-12100	DN150	112	102	91	108	128	82	0.1