



**AVK MAGNUS PE100 BALL VALVES**  
Fusible ends / Minimum full bore on all body sizes  
Valve sizes OD63 up to OD180

**85/50**  
**008**  
**HDPE/BV+SE+2PP**

The AVK MAGNUS universal ball valve is for use in the isolation of water & gas on domestic, commercial and industrial premises. The ends are designed for butt-/electro-fusion making the valve an integral part of the fully welded leak-free pipe system.  
The valve is designed, manufactured and approved to worldwide leading standards.

**Features**

- Robust design, suitable for most harsh environments
- Material selection body and spigot (PE100-RC) offering excellent resistance to crack propagation
- Seat, ball and grease combination ensuring low operating torques and avoids sticking over time
- Selected ball material offering good scratch resistance
- Grease with minimal wearing off from the lubricated surfaces for improved long term performance
- With stem extension and purge points
- White bearing ring for easy identification universal valve
- Traccoding (barcode) + AVIT (QR code) - asset management to record, track and identify where valves are located and ensure traceability at all times
- Seat compression of large sealing surfaces precisely set via separate pre-assembly
- Flexible spindle shaft to ensure equal compression around the O-rings when loaded by internal pressure
- Fully automated socket welding of stem extension and purge pipes for optimal reliability
- Threaded metal bush in purge valve spigot for durable and secure connections
- BSP thread 1" suitable for universal flares
- Stainless steel lever for easy operation of purge valve
- Delivered with pressure retaining plug

**Tests/Approvals (main valve)**

EN1555-4, ISO4437-4, GB15558.3 and EN12201-4



Expect... **AVR**

**AVK MAGNUS PE100 BALL VALVES**  
 Fusible ends / Minimum full bore on all body sizes  
 Valve sizes OD63 up to OD180

**85/50**  
**008**  
**HDPE/BV+SE+2PP**

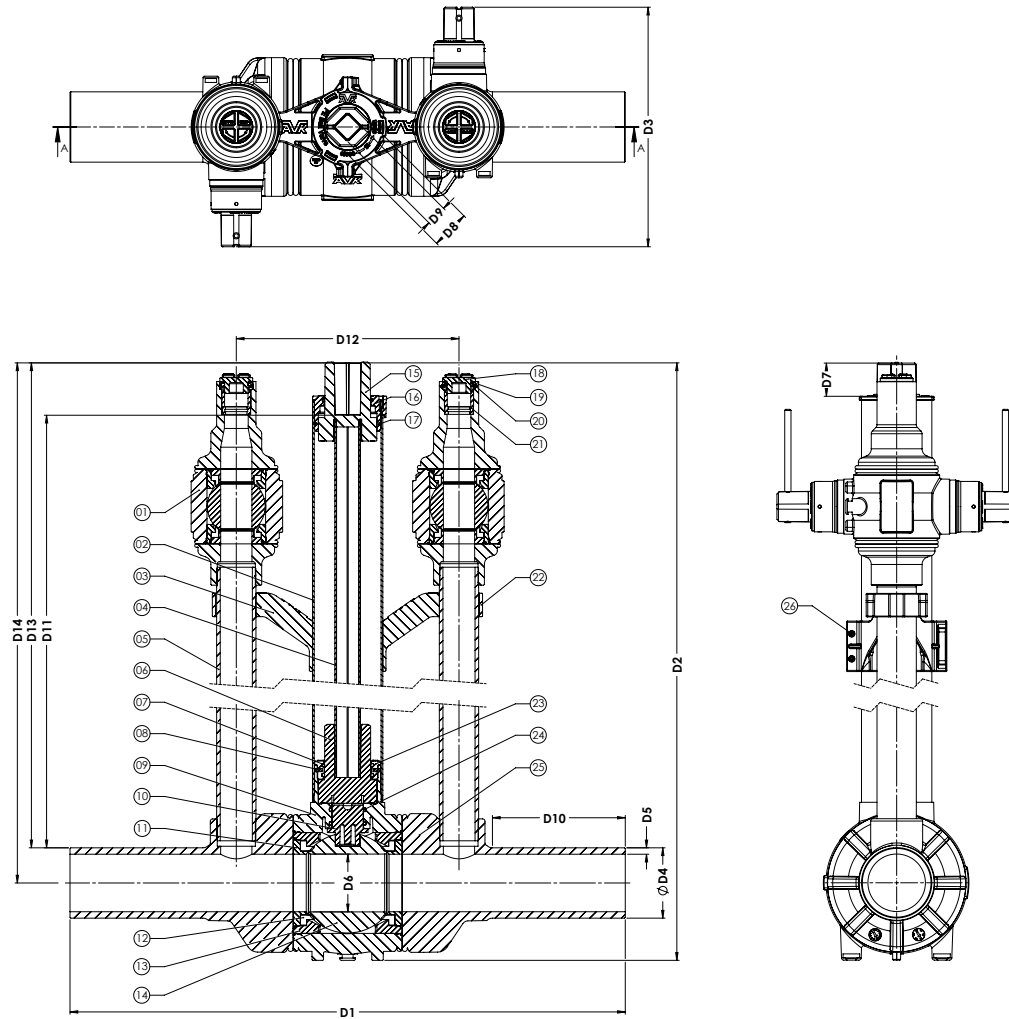

**Component list**

1. Purge valve	PE100-RC	14. Ball	POM
2. Extension pipe	PE100	15. Connector SE	PA-GF
3. Support bracket	HDPE	16. Bearing ring SE	PA
4. Profile	Galvanized steel	17. O-ring	NBR-70
5. Purge pipe	PE100	18. Threaded plug	POM
6. Connector	PA-GF	19. O-ring	VITON
7. O-ring	NBR-70	20. O-ring	FPM
8. Locking pin	PVC	21. Threaded bush	AISI 304
9. Body	PE100-RC	22. Support bracket	HDPE
10. Stem	POM	23. Bearing ring	PA
11. Support ring	PE100-RC	24. O-ring	NBR-70
12. Ball seat	NBR-70	25. Spigot	PE100-RC
13. Seat retainer	PE100-RC	26. PT screw	Galvanized steel

**Reference nos. and dimensions**

SDR	AVK ref. nos.	Valve size mm	D1 mm	D2 mm	D3 mm	D4 mm	D5 mm	D6 mm	D7 mm	D8 mm	D9 mm	D10 mm	D11 mm	D12 mm	D13 mm	D14 mm	Weight kg
11	85-063-501200400522	OD63/DN50	715	810	305	63	5.8	50	40	49.6	25.5	170	635	285	700	730	8.7
11	85-090-502200400522	OD90/DN80	710	855	305	90	8.2	74	40	49.6	25.5	170	645	285	710	755	12.0
11	85-110-501200400522	OD110/DN100	715	875	305	110	10.0	86	40	49.6	25.5	170	645	285	710	765	13.8
11	85-125-501200400522	OD125/DN100	715	875	305	125	11.4	86	40	49.6	25.5	170	635	285	700	765	14.6
11	85-160-501200400522	OD160/DN150	795	1045	305	160	14.6	120	40	49.6	25.5	170	750	355	815	895	26.3
11	85-180-501200400522	OD180/DN150	795	1045	305	180	16.4	120	40	49.6	25.5	170	740	355	805	895	27.1
17.6	85-090-501250400522	OD90/DN80	710	855	305	90	5.2	74	40	49.6	25.5	170	645	285	710	755	11.9
17.6	85-110-501250400522	OD110/DN100	715	875	305	110	6.3	86	40	49.6	25.5	170	645	285	710	765	13.6
17.6	85-125-500250400522	OD125/DN100	715	875	305	125	7.1	86	40	49.6	25.5	170	635	285	700	765	14.4
17.6	85-160-501250400522	OD160/DN150	795	1045	305	160	9.1	120	40	49.6	25.5	170	750	355	815	895	26.0
17.6	85-180-500250400522	OD180/DN150	795	1045	305	180	10.3	120	40	49.6	25.5	170	740	355	805	895	26.8

Above dimensions are subject to tolerances

The designs, materials and specifications shown are subject to change without notice due to the continuous development of our product programme.