



AVK MAGNUS PE100 BALL VALVES
Fusible ends / Minimum full bore on all body sizes
Valve sizes OD63 up to OD180

85/50
006
HDPE/BV+SE+1PP

The AVK MAGNUS universal ball valve is for use in the isolation of water & gas on domestic, commercial and industrial premises. The ends are designed for butt-/electro-fusion making the valve an integral part of the fully welded leak-free pipe system.
The valve is designed, manufactured and approved to worldwide leading standards.

Features

- Robust design, suitable for most harsh environments
- Material selection body and spigot (PE100-RC) offering excellent resistance to crack propagation
- Seat, ball and grease combination ensuring low operating torques and avoids sticking over time
- Selected ball material offering good scratch resistance
- Grease with minimal wearing off from the lubricated surfaces for improved long term performance
- With stem extension and purge point
- White bearing ring for easy identification universal valve
- Traccoding (barcode) + AVIT (QR code) - asset management to record, track and identify where valves are located and ensure traceability at all times
- Seat compression of large sealing surfaces precisely set via separate pre-assembly
- Flexible spindle shaft to ensure equal compression around the O-rings when loaded by internal pressure
- Fully automated socket welding of stem extension and purge pipes for optimal reliability
- Threaded metal bush in purge valve spigot for durable and secure connections
- BSP thread 1" suitable for universal flares
- Stainless steel lever for easy operation of purge valve
- Delivered with pressure retaining plug

Tests/Approvals

EN1555-4, ISO4437-4, GB15558.3 and EN12201-4



Expect... **AVR**

AVK MAGNUS PE100 BALL VALVES
 Fusible ends / Minimum full bore on all body sizes
 Valve sizes OD63 up to OD180

85/50
006
HDPE/BV+SE+1PP

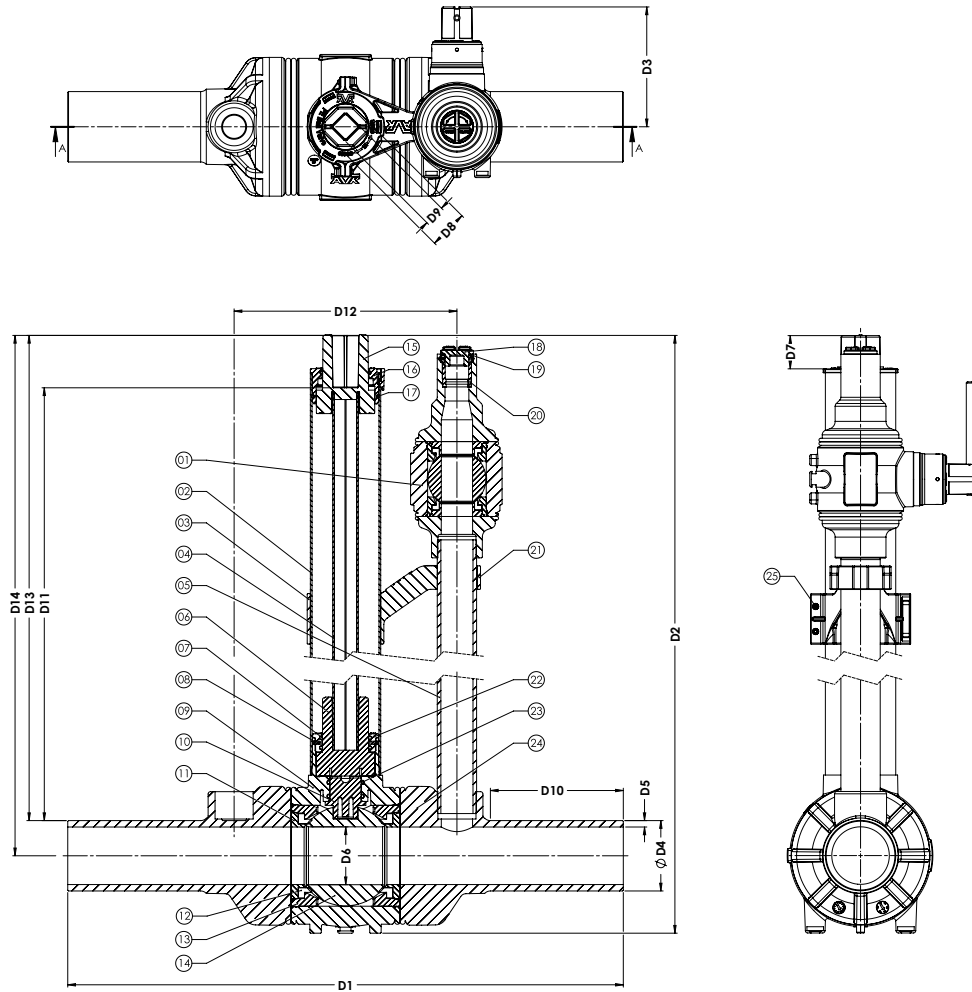

Component list

1. Purge valve	PE100-RC	14. Ball	POM
2. Extension pipe	PE100	15. Connector SE	PA-GF
3. Support bracket	HDPE	16. Bearing ring SE	PA
4. Profile	Galvanized steel	17. O-ring	NBR-70
5. Purge pipe	PE100	18. Threaded plug	POM
6. Connector	PA-GF	19. O-ring	NBR-70
7. O-ring	NBR-70	20. Threaded bush	AISI 304
8. Locking pin	PVC	21. Support bracket	HDPE
9. Body	PE100-RC	22. Bearing ring	PA
10. Stem	POM	23. O-ring	NBR-70
11. Support ring	PE100-RC	24. Spigot	PE100-RC
12. Ball seat	NBR-70	25. PT screw	Galvanized steel
13. Seat retainer	PE100-RC		

Reference nos. and dimensions

SDR	AVK ref. nos	Valve size mm	D1 mm	D2 mm	D3 mm	D4 mm	D5 mm	D6 mm	D7 mm	D8 mm	D9 mm	D10 mm	D11 mm	D12 mm	D13 mm	D14 mm	Weight kg
11	85-063-501200400521	OD63/DN50	715	810	152.5	63	5.8	50	40	49.6	25.5	170	635	285	700	730	6.8
11	85-090-502200400521	OD90/DN80	710	855	152.5	90	8.2	74	40	49.6	25.5	170	645	285	710	755	9.9
11	85-110-501200400521	OD110/DN100	715	875	152.5	110	10.0	86	40	49.6	25.5	170	645	285	710	765	11.9
11	85-125-501200400521	OD125/DN100	715	875	152.5	125	11.4	86	40	49.6	25.5	170	635	285	700	765	12.6
11	85-160-501200400521	OD160/DN150	795	1045	152.5	160	14.6	120	40	49.6	25.5	170	750	355	815	895	24.2
11	85-180-501200400521	OD180/DN150	795	1045	152.5	180	16.4	120	40	49.6	25.5	170	740	355	805	895	25.0
17.6	85-090-501250400521	OD90/DN80	710	855	152.5	90	5.2	74	40	49.6	25.5	170	645	285	710	755	9.8
17.6	85-110-501250400521	OD110/DN100	715	875	152.5	110	6.3	86	40	49.6	25.5	170	645	285	710	765	11.7
17.6	85-125-500250400521	OD125/DN100	715	875	152.5	125	7.1	86	40	49.6	25.5	170	635	285	700	765	12.4
17.6	85-160-501250400521	OD160/DN150	795	1045	152.5	160	9.1	120	40	49.6	25.5	170	750	355	815	895	23.9
17.6	85-180-500250400521	OD180/DN150	795	1045	152.5	180	10.3	120	40	49.6	25.5	170	740	355	805	895	24.7

Above dimensions are subject to tolerances

The designs, materials and specifications shown are subject to change without notice due to the continuous development of our product programme.